



Model 3A

Ratchet Leverage Arbor Press

Instruction and Parts list

MODEL 3A

<u>Item</u>	<u>Part Name</u>	<u>Part No.</u>
1	Frame	245
2	Ram Cap	296
3	Table Plate Assembly	701226
4	Leverweight	258
5	Pawl	297
6	Ram (2" x 2" x 23")	253
7	Retaining Ring	67955
8	Pawl Pin	255
9	Spindle	256
10	Handbrake (2 required)	214
11	Handbrake Clamp	215
12	Handbrake Stud	223
13	Rest Pin	280
14	Handle	283
15	Handwheel	257

Please contact factory for current prices.

Ordering information: Please order all repair parts by part number and name, also mention model number of press. All parts are shipped F.O.B. Factory in Grand Haven, MI.

Lubrication: Keep all working parts of the press well oiled for easier operation. Also keep a light film of oil over the entire surface of the ram to prevent rust.

DAKE

Division of JSJ Corp.
724 Robbins Road
Grand Haven, MI 49417

Phone: 616-842-7110 800-937-3253
Fax: 616-842-0859 800-846-3253
E-Mail: customerservice@dakecorp.com
technicalservice@dakecorp.com
Website: www.dakecorp.com

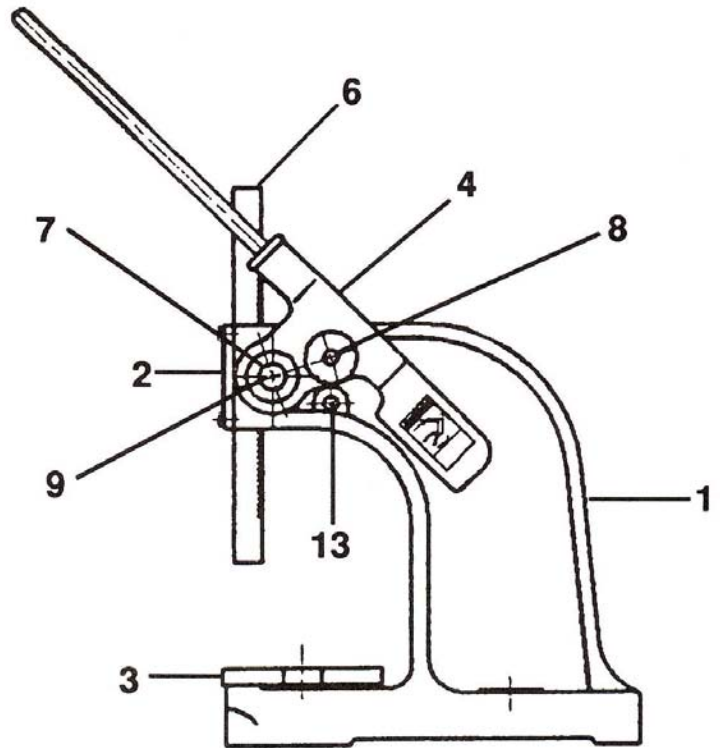
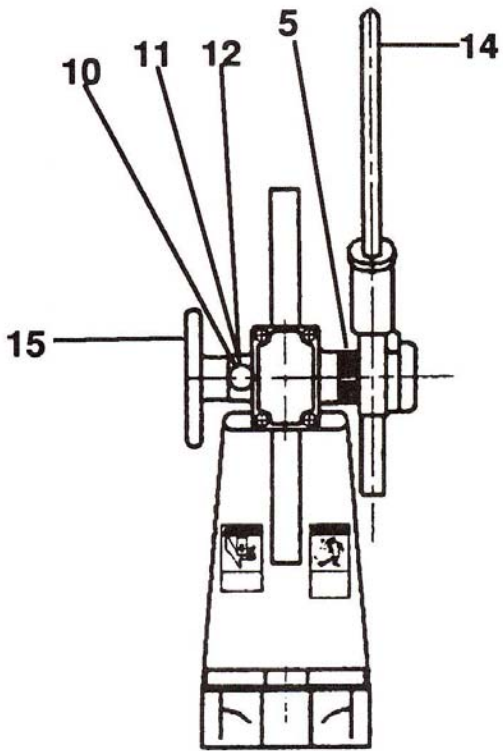

Warning Label:
300168

⚠ WARNING		
Establish solid footing to prevent falls.	Keep hand away from point of operation. Read instructions.	Guard workpiece to prevent projectiles from reaching operator. Wear eye protection.

⚠ WARNING
Equipment must be securely anchored to prevent tipping.

Warning Label:
79979



SAFETY

This is the safety alert symbol. When you see this symbol on your press, be alert to the potential for personal injury.

Follow recommended precautions and safe operating practices.

Carefully read all safety messages in these instructions and on your press safety signs. Keep safety labels in good condition. Replace missing or damaged safety labels.

This machine is intended to be operated by one person. This person should be conscious of the press ram movement not only for themselves but also for persons in the immediate area of the machine.

Under no circumstances increase the leverage ratio of the press by using a longer handle or by placing a pipe over the handle. Never hammer on top of the ram.