



# THOMAS

## USE AND MAINTENANCE MANUAL

**275 SUPER CUT**  
**300 SUPER CUT**  
**315 SUPER CUT**

# THOMAS





## Contents

Contents .....	"	2	7.1 - Disk head .....	"	8
Ordering spare parts .....	"	2	7.2 - Vice .....	"	8
Guarantee .....	"	2	7.3 - Cutting angle adjustment .....	"	9
Machine certification and identification marking .....	"	3	7.4 - Changing the disk .....	"	9
<b>CHAPTER 1</b> .....			7.5 - Changing the lubricating coolant pump .....	"	9
<b>Reference to accident-prevention regulations .....</b>	"	4	<b>CHAPTER 8</b> .....		
1.1 - Advice for the operator .....	"	4	<b>Routine and special maintenance .....</b>	"	9
1.2 - Location of shields against accidental contact with the tool .....	"	4	8.1 - Daily maintenance .....	"	9
1.3 - Electrical equipment according to European Standard "CENELEC EN 60 204-1" (1992) .....	"	4	8.2 - Weekly maintenance .....	"	9
1.4 - Emergencies according to European Standard "CENELEC EN 60 204-1" (1992) .....	"	4	8.3 - Monthly maintenance .....	"	9
<b>CHAPTER 2</b> .....			8.4 - Six-monthly maintenance .....	"	9
<b>Recommendations and advice for use .....</b>	"	4	8.5 - Oils for lubricating coolant .....	"	9
2.1 - Recommendations and advice for using the machine ..	"	4	8.6 - Oil disposal .....	"	10
<b>CHAPTER 3</b> .....			8.7 - Special maintenance .....	"	10
<b>Technical characteristics .....</b>	"	5	<b>CHAPTER 9</b> .....		
3.1 - Table of cutting capacity and technical details .....	"	5	<b>Material classification and choice of tool .....</b>	"	10
<b>CHAPTER 4</b> .....			9.1 - Definition of materials .....	"	10
<b>Machine dimensions - Transport - Installation</b>			9.2 - Choosing the disk .....	"	10
<b>Dismantling .....</b>	"	6	9.3 - Teeth pitch .....	"	11
4.1 - Machine dimensions .....	"	6	9.4 - Cutting and advance speed .....	"	11
4.2 - Transport and handling of the machine .....	"	6	9.5 - Running in the disk .....	"	11
4.3 - Minimum requirements for the premises housing the machine .....	"	6	9.6 - Disk structure .....	"	11
4.4 - Anchoring the machine .....	"	7	9.7 - Type of disks .....	"	11
4.5 - Instructions for electrical connection .....	"	7	Tooth shape .....	"	11
4.6 - Instructions for assembly of the loose parts and accessories .....	"	7	Tooth cutting angle .....	"	11
4.7 - Disactivating the machine .....	"	7	9.7.1 - Table of recommended cutting parameters .....	"	12
4.8 - Dismantling .....	"	7	9.7.2 - Table of cutting speed according to disk diameter .....	"	12
<b>CHAPTER 5</b> .....			<b>CHAPTER 10</b> .....		
<b>Machine functional parts .....</b>	"	7	<b>Machine components .....</b>	"	13
5.1 - Operating head .....	"	7	10.1- List of spare parts .....	"	13
5.2 - Vice .....	"	7	<b>CHAPTER 11</b> .....		
5.3 - Bed .....	"	8	<b>Wiring diagrams .....</b>	"	17
<b>CHAPTER 6</b> .....			<b>CHAPTER 12</b> .....		
<b>Description of the operating cycle .....</b>	"	8	<b>Troubleshooting .....</b>	"	19
6.1 - Starting up and cutting cycle .....	"	8	12.1- Blade and cutting diagnosis .....	"	19
<b>CHAPTER 7</b> .....			12.2- Electrical components diagnosis .....	"	21
<b>Regulating the machine .....</b>	"	8	<b>CHAPTER 13</b> .....		
			<b>Noise tests .....</b>	"	21
			<b>CHAPTER 14</b> .....		
			<b>Optional .....</b>	"	22
			14.1 - Pneumatic vice .....	"	22
			14.2 - Connection to the pneumatic system .....	"	22
			<b>Plates and labels .....</b>	"	22
			<b>Notes .....</b>	"	23

## Ordering spare parts

- When ordering spare parts you must state:  
MACHINE MODEL  
SERIAL NUMBER  
PART REFERENCE NUMBER

Without these references WE WILL NOT SUPPLY the spares. See point 10.1 - list spare parts -.

## Guarantee

- The Company guarantees that the machine to which this manual refers has been designed and built to comply with safety regulations and that it has been tested for functionality in the factory.
- The machine is guaranteed for 12 months: the guarantee does not cover the electric motors, electric components, pneumatic components or any damage due to dropping or to bad machine management, the failure to observe maintenance standards or bad handling by the operator.
- The buyer has only the right to replacement of the faulty parts, while transport and packing costs are at his expense.
- The serial number on the machine is a primary reference for the guarantee, for after-sales assistance and for identifying the machine for any necessity.



## Machine certification and identification marking

### MACHINE LABEL

<b>THOMAS S.p.A.</b>	<b>CE</b>
via Pasubio, 32 36033 ISOLA VIC. - ITALIA	
<b>MODEL</b>	SUPER CUT
<b>TYP</b>	
<b>SERIAL NUMBER</b>	
<b>YEAR OF MANUFACTURE</b>	

(Space reserved for the NAME and STAMP of the DEALER and/or IMPORTER)

## 1 REFERENCE TO ACCIDENT-PREVENTION REGULATIONS

This machine has been built to comply with the national and community accident-prevention regulations in force. Improper use and/or tampering with the safety devices will relieve the manufacturer of all responsibility.



### 1.1 - Advice for the operator

- Check that the voltage indicated on the plate, normally fixed to the machine motor, is the same as the line voltage.
- Check the efficiency of your electric supply and earthing system; connect the power cable of the machine to the socket and the earth lead (yellow-green in colour) to the earthing system.
- When the tool head is in rest position (raised), the toothed disk must be stationary.
- It is forbidden to work on the machine without its shields (these are all white, grey or blue in colour).
- Always disconnect the machine from the power socket before changing the disk or carrying out any maintenance job, even in the case of abnormal machine operation.
- It is forbidden to disconnect the "man present" device, known more correctly in the EEC as the "safety switch with hold-down action".
- Always wear suitable eye protection.
- Never put your hands or arms into the cutting area while the machine is operating.
- Do not shift the machine while it is cutting.
- Do not wear loose clothing with sleeves that are too long, gloves that are too big, bracelets, chains or any other object that could get caught in the machine during operation; tie back long hair.
- Keep the area free of equipment, tools or any other object.
- Perform only one operation at a time and never have several objects in your hands at the same time. Keep your hands as clean as possible.
- All internal and/or internal operations, maintenance or repairs, must be performed in a well-lit area or where there is sufficient light from extra sources so as to avoid the risk of even slight accidents.

### 1.2 - Location of shields against accidental contact with the tool

- Green metal shield screwed onto the disk head.
- Self-regulating mobile blue plastic shield, fitted coaxially with the fixed shield.

### 1.3 - Electrical equipment according to European Standard "CENELEC EN 60 204-1" which assimilates, with some integrating modifications, the publication "IEC 204-1"

- The electrical equipment ensures protection against electric shock as a result of direct or indirect contact. The active parts of this equipment are housed in a box to which access is limited by screws that can only be removed with a special tool; the parts are fed with alternating current at low voltage (24 V). The equipment is protected against splashes of water and

- dust.
- Protection of the system against short circuits is ensured by means of rapid fuses and earthing; in the event of motor overload, protection is provided by a thermal probe.
- In the event of a power cut, the specific start-up button must be reset.
- The machine has been tested in conformity with point 20 of EN 60204.

### 1.4 - Emergencies according to European Standard "CENELEC EN 60 204-1"

- In the event of incorrect operation or of danger conditions, the machine may be stopped immediately by pressing the red mushroom button.

NOTE: Resetting of machine operation after each emergency stop is achieved by reactivating the specific restart button.

## 2 RECOMMENDATIONS AND ADVICE FOR USE

### 2.1 - Recommendations and advice for using the machine

- The machine has been designed to cut metal building materials, with different shapes and profiles, used in workshops, turner's shops and general mechanical structural work.
- Only one operator is needed to use the machine.

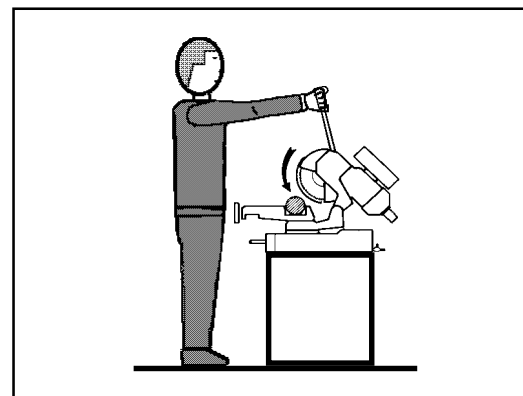

- To obtain good running-in of the machine it is advisable to start using it at intervals of about half an hour. This operation should be repeated two or three times, after which the machine may be used continuously.
- Before starting each cutting operation, ensure that the part is firmly gripped in the vice and that the end is suitably supported.
- Do not use disks of a different size from those stated in the machine specifications.
- If the disk gets stuck in the cut, release the running button immediately, switch off the machine, open the vice slowly, remove the part and check that the disk or its teeth are not broken. If they are broken, change the tool.
- Before carrying out any repairs on the machine, consult the dealer or apply to THOMAS.

## 3 TECHNICAL CHARACTERISTICS

### 3.1 - Table of cutting capacity and technical details

#### 275 SUPER CUT

0°	85	70	95 x 60
45° DX - SX	72	65	75 x 60

2-speed three-phase electric motor	KW	1,1 ÷ 1,5
1-speed single-phase electric motor	KW	1,5
Max. electric absorption	KW	1,55
Oil-bath reduction unit	i	34 : 1
Max. blade diameter	mm	275
Min. blade diameter	mm	250
Blade rotation speed	rpm	41 ÷ 82
Vice opening	mm	120
Machine Weight	KG	123
Coolant liquid	L	5
Working table height with base	mm	980

#### 300 SUPER CUT

0°	90	75	100 x 65
45° DX - SX	80	70	80 x 60

2-speed three-phase electric motor	KW	1,2 ÷ 1,6
1-speed single-phase electric motor	KW	1,5
Max. electric absorption	KW	1,55
Oil-bath reduction unit	i	34 : 1
Max. blade diameter	mm	300
Min. blade diameter	mm	250
Blade rotation speed	rpm	41 ÷ 82
Vice opening	mm	120
Machine Weight	KG	125
Coolant liquid	L	5
Working table height with base	mm	980

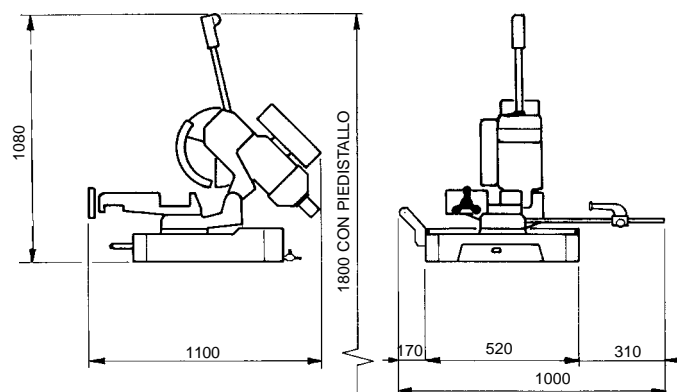
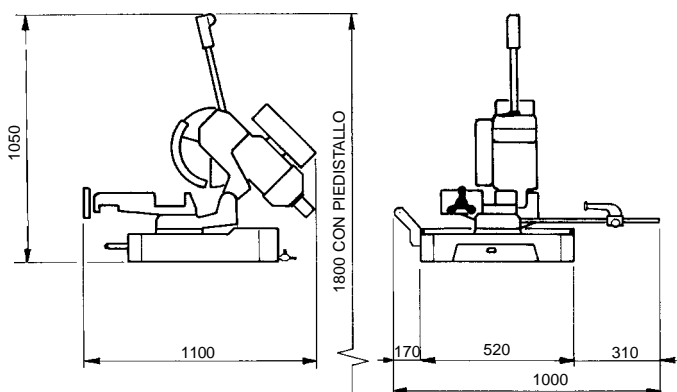



## MACHINE DIMENSIONS

### 4 TRANSPORT INSTALLATION DISMANTLING

## 315 SUPER CUT

0°	95	82	110 x 70
45° DX - SX	90	80	85 x 70

2-speed three-phase electric motor	KW	1,3 ÷ 1,9
1-speed single-phase electric motor	KW	1,5
Max. electric absorption	KW	1,95
Oil-bath reduction unit	i	34 : 1
Max. blade diameter	mm	315
Min. blade diameter	mm	250
Blade rotation speed	rpm	41 ÷ 82
Vice opening	mm	120
Machine Weight	KG	128
Coolant liquid	L	5
Working table height with base	mm	980



### 4.1 - Transport and handling of the machine

If the machine has to be shifted in its own packing, use a fork-lift truck or sling it with straps as illustrated.

### 4.2 - Minimum requirements for the premises housing the machine

- Mains voltage and frequency complying with the machine motor characteristics.
- Environment temperature from -10 °C to +50 °C.
- Relative humidity not over 90%.

### 4.3 - Anchoring the machine

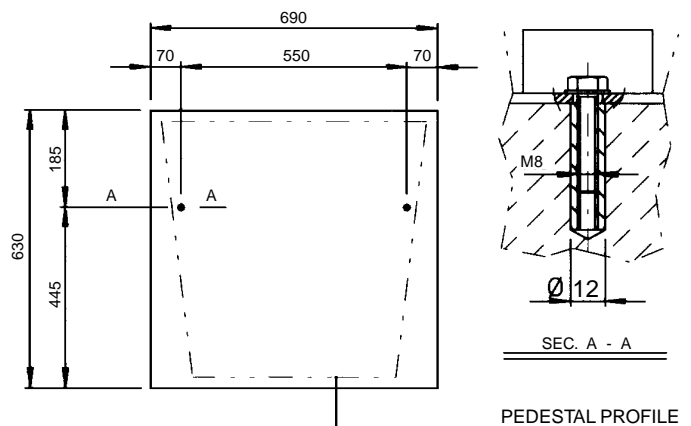
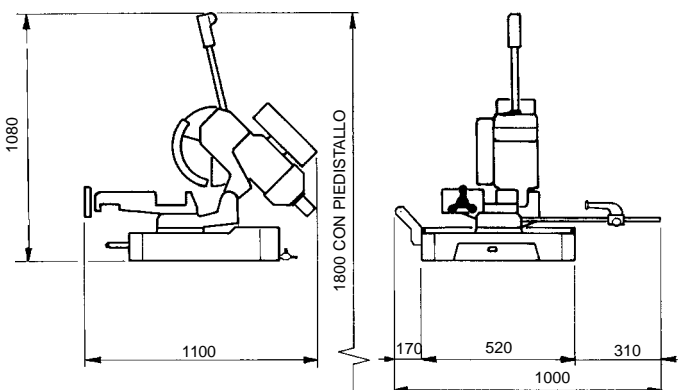

- Position the machine on a firm cement floor maintaining, at the rear, a minimum distance of 800 mm from the wall; anchor it to the ground as shown in the diagram, using screws and expansion plugs or tie rods sunk in cement, ensuring that it is sitting level.

## 4.4 - Instructions for electrical connection

- The machine is not provided with an electric plug, so the customer must fit a suitable one for his own working conditions:

### 1 - WIRING DIAGRAM FOR THREE-PHASE MACHINE - SOCKET FOR A 16A PLUG

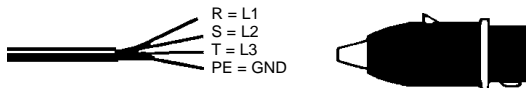

### 2 - WIRING DIAGRAM FOR THE SINGLE-PHASE SYSTEM SOCKET FOR A 16A PLUG

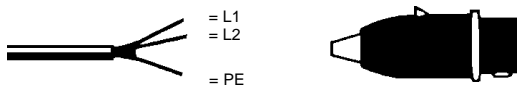

## 4.5 - Instructions for assembly of the loose parts and accessories

Fit the components supplied as indicated in the photo:

- part. 1 Screw the lever onto the head and fix it
- part. 2 Fit the bar holding rod
- part. 3 Fix the pedestal firmly onto the base ( optional )
- part. 4 Fit and align the roller carrying arm on the counter-vice bench.

## 4.6 - Disactivating the machine

- If the sawing machine is to be out of use for a long period, it is advisable to proceed as follows:

- 1) detach the plug from the electric supply panel
- 2) release the head return spring
- 3) empty the coolant tank
- 4) carefully clean and grease the machine
- 5) if necessary, cover the machine.

## 4.7 - Dismantling

(because of deterioration and/or obsolescence)

### General rules

If the machine is to be permanently demolished and/or scrapped, divide the material to be disposed of according to type and composition, as follows:

- 1) Cast iron or ferrous materials, composed of **metal alone**, are **secondary raw materials**, so they may be taken to an iron foundry for re-smelting after having removed the contents (classified in point 3);
- 2) electrical components, including the cable and electronic material (magnetic cards, etc.), fall within the category of material classified as being **assimilable to urban waste** according to the laws of the European community, so they may be set aside for collection by the public waste disposal service;
- 3) old mineral and synthetic and/or mixed oils, emulsified oils and greases are **special refuse**, so they must be collected, transported and subsequently disposed of by the old oil disposal service.

NOTE: since standards and legislation concerning refuse in general is in a state of continuous evolution and therefore subject to changes and variations, the user must keep informed of the regulations in force at the time of disposing of the machine tool, as these may differ from those described above, which are to be considered as a general guide line.

# 5 MACHINE FUNCTIONAL PARTS

## 5.1 - Operating head

- Machine part composed of the parts that transmit movement (motor, reduction unit), the lubricating coolant pump and the electrical components.



## 5.2 - Vice

- System for gripping material during the cutting operation, operated with handwheel and fast manual blocking lever. It is provided with an anti-burr device for blocking the part that is to be cut.



## 5.3 - Bed

- Support structure for the OPERATING HEAD (rotating arm for gradual cutting, with respective blocking system), the VICE, the BAR STOP, the material support ROLLER and the housing for the cutting coolant TANK.

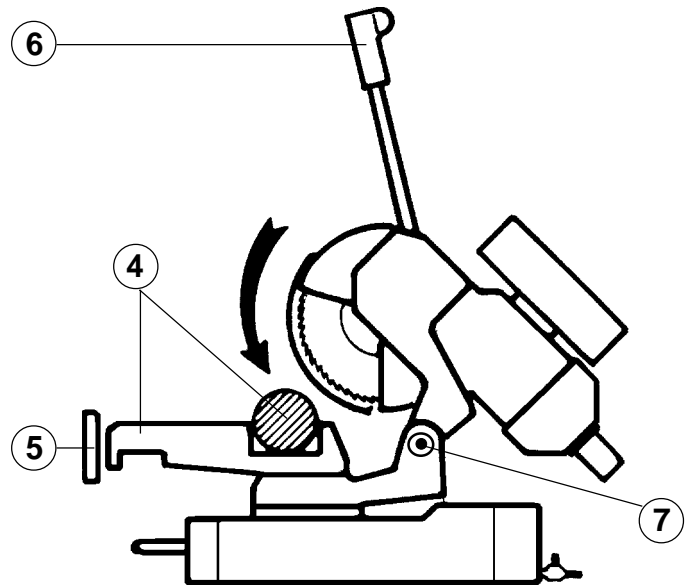

and that sufficient coolant is coming out.

The cropper is now ready to start work, bearing in mind that the CUTTING SPEED and the TYPE of DISC - combined with a suitable descent of the head - are of decisive importance for cutting quality and for machine performance (for further details on this topic, see below in the chapter on “Material classification and choice of disks”).

- When starting to cut with a new disk, in order to safeguard its life and efficiency, the first two or three cuts must be made while exerting a slight pressure on the part, so that the time taken to cut is about double the normal time (see below in the chapter on “Material classification and choice of disks” in the section on *Running in the disk*).

- Press the red emergency button ( 1 ) when there are conditions of danger or malfunctions in general, so as to stop machine operation immediately.

## 6 DESCRIPTION OF THE OPERATING CYCLE

Before operating, all the main organs of the machine must be set in optimum conditions (see the chapter on “Regulating the machine”).

### 6.1 - Starting up and cutting cycle



- Ensure that the machine is not in emergency stop condition; if it is, release the red mushroom button ( 1 ).
- Select the cutting speed on the switch ( 3 ):  
position 1 = 41 rpm.  
position 2 = 82 rpm.
- Press the start/reset button ( 2 ): its green light will go on.
- Place material to be cut in the vice ( 4 ). Close jaws against piece, keeping a distance of approx. 3 - 4 mm then clamp with lever.
- Grip the handle ( 6 ) of the HEAD control arm and press the button, checking that the disk is turning in the direction indicated (if not, invert the two phase leads):

## 7 REGULATING THE MACHINE

### 7.1 - Disk head

- If excessive axial play is found on the hinge, it will be sufficient to tighten the screws ( 7 ), paying attention not to make the joint too tight.

### 7.2 - Vice

- The device does not require any particular adjustment.

## 7.3 - Cutting angle adjustment

- Release lever ( 1 ), rotate the cutting head and make sure that the wanted cutting angle perfectly meets with the reference index before locking with the lever ( 1 ).

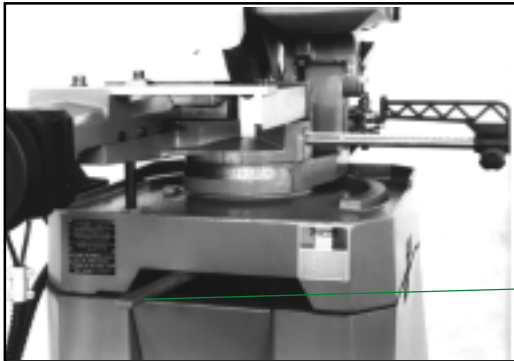

1

**BEFORE PERFORMING THE FOLLOWING OPERATIONS, THE ELECTRIC POWER SUPPLY AND THE POWER CABLE MUST BE COMPLETELY DISCONNECTED.**

## 7.4 - Changing the disk

To change the disk:

- Release the mobile yellow, white or orange guard and turn it back.
- Block a piece of wood in the vice and lean the disk on it.
- Insert the special spanner provided and remove the screw ( 1 ), slackening it in a clockwise direction because it has a left-handed thread, then slip off the flange that holds the disk.
- Fit the new disk, checking the cutting direction of the teeth, then replace the flange, the screw and the mobile white, yellow or orange guard.

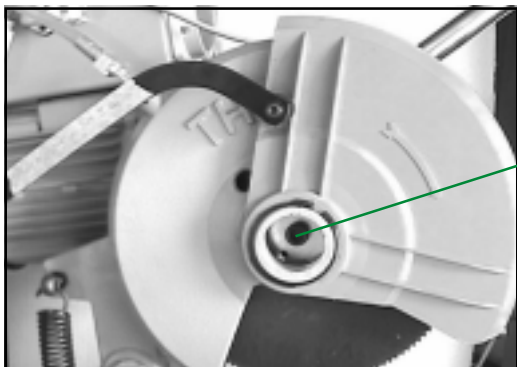

1

## 7.5 - Changing the lubricating coolant pump

- Takes the pipes of the lubricating-refrigerating system off.
- Remove the fastening screws and replace the little pump, being careful to keep the driving stem centred on the drive shaft bearing.

## 8 ROUTINE AND SPECIAL MAINTENANCE

THE MAINTENANCE JOBS ARE LISTED BELOW, DIVIDED INTO DAILY, WEEKLY, MONTHLY AND SIX-MONTHLY INTERVALS. IF THE FOLLOWING OPERATIONS ARE NEGLECTED, THE RESULT WILL BE PREMATURE WEAR OF THE MACHINE AND POOR PERFORMANCE.

### 8.1 - Daily maintenance

- General cleaning of the machine to remove accumulated shavings.
- Top up the level of lubricating coolant.
- Check the disk for wear.
- Lift the head into a high position to avoid yield stress on the return spring.
- Check functionality of the shields and emergency stops.

### 8.2 - Weekly maintenance

- More accurate general cleaning of the machine to remove shavings, especially from the lubricant fluid tank.
- Clean the filter of the pump suction head and the suction area.
- Clean and grease the screw and the sliding guide of the vice.
- Clean the disk housing.
- Sharpen the disk teeth.

### 8.3 - Monthly maintenance

- Check tightness of the screws on the motor, the pump, the jaws and shields.
- Check that the shields are unbroken.
- Grease the head hinge pin.

### 8.4 - Six-monthly maintenance

- Change the oil in the reduction unit using oil type GEARCO 85W-140 by NATIONAL CHEMSERACH or MOBIL GLYCOLE 30 or KLUBER SINTHESO 460 EP or an equivalent oil, proceeding as follows:

- Remove the connecting plug from the electric box and unscrew the head moving lever.
- Drain off the old oil from the cap at the side ( 1 ).
- Pour in new oil up to the mark ( 2 ), through the lever fixing hole, keeping the head in a horizontal position.
- Reassemble all the parts.



2

1

- Check continuity of the equipotential protection circuit

### 8.5 - Oils for lubricating coolant

Considering the vast range of products on the market, the user can choose the one most suited to his own requirements, using as reference the type SHELL LUTEM OIL ECO. THE MINIMUM PERCENTAGE OF OIL DILUTED IN WATER IS 8 - 10 %.



## 8.6 - Oil disposal

The disposal of these products is controlled by strict regulations. Please see the Chapter on "Machine dimensions - Transport - Installation" in the section on *Dismantling*.

## 8.7 - Special maintenance

Special maintenance operations must be carried out by skilled personnel. However, we advise contacting THOMAS or their dealer and/or importer. The term special maintenance also covers the resetting of protection and safety equipment and devices.

# 9 MATERIAL CLASSIFICATION AND CHOICE OF TOOL

Since the aim is to obtain excellent cutting quality, the various parameters such as **hardness of the material, shape and thickness, transverse cutting section** of the part to be cut, **choice of the type of cutting disk, cutting speed** and **control of head descent**, must be suitably combined. These specifications must therefore be harmoniously combined in a single operating condition according to practical consi-

derations and common sense, so as to achieve an optimum condition that does not require countless operations to prepare the machine when there are many variations in the job to be performed. The various problems that crop up from time to time will be solved more easily if the operator has a good knowledge of these specifications.

WE THEREFORE ADVISE YOU ALWAYS TO CHOOSE ORIGINAL SPARE DISKS THAT GUARANTEE SUPERIOR QUALITY AND PERFORMANCE.

## 9.1 - Definition of materials

The table at the foot of the page lists the characteristics of the materials to be cut, so as to choose the right tool to use.

## 9.2 - Choosing the disk

First of all the pitch of the teeth must be chosen, suitable for the material to be cut, according to these criteria:

- parts with a thin and/or variable section such as profiles, pipes and plate, need close toothing, so that the number of teeth used simultaneously in cutting is from 3 to 6;
- parts with large transverse sections and solid sections need widely spaced toothing to allow for the greater volume of the shavings and better tooth penetration;
- parts made of soft material or plastic (light alloys, mild bronze, teflon, wood, etc.) also require widely spaced toothing.

TYPES OF STEEL						CHARACTERISTICS		
USE	I UNI	D DIN	F AF NOR	GB SB	USA AISI-SAE	Hardness BRINELL HB	Hardness ROCKWELL HRB	R=N/mm2
Construction steels	Fe360	St37	E24	----	----	116	67	360÷480
	Fe430	St44	E28	43	----	148	80	430÷560
	Fe510	St52	E36	50	----	180	88	510÷660
Carbon steels	C20	CK20	XC20	060 A 20	1020	198	93	540÷690
	C40	CK40	XC42H1	060 A 40	1040	198	93	700÷840
	C50	CK50	----	----	1050	202	94	760÷900
	C60	CK60	XC55	060 A 62	1060	202	94	830÷980
Spring steels	50CrV4	50CrV4	50CV4	735 A 50	6150	207	95	1140÷1330
	60SiCr8	60SiCr7	----	----	9262	224	98	1220÷1400
Alloyed steels for hardening and tempering and for nitriding	35CrMo4	34CrMo4	35CD4	708 A 37	4135	220	98	780÷930
	39NiCrMo4	36CrNiMo4	39NCD4	----	9840	228	99	880÷1080
	41CrAlMo7	41CrAlMo7	40CADG12	905 M 39	----	232	100	930÷1130
Alloyed casehardening steels	18NiCrMo7	----	20NCD7	En 325	4320	232	100	760÷1030
	20NiCrMo2	21NiCrMo2	20NCD2	805 H 20	4315	224	98	690÷980
Steel for bearings	100Cr6	100Cr6	100C6	534 A 99	52100	207	95	690÷980
Tool steel	52NiCrMoKU	56NiCrMoV7	----	----	----	244	102	800÷1030
	C100KU	C100W1	----	BS 1	S-1	212	96	710÷980
	X210Cr13KU	X210Cr12	Z200C12	BD2 - BD3	D6 - D3	252	103	820÷1060
	58SiMo8KU	----	Y60SC7	----	S5	244	102	800÷1030
Stainless steel	X12Cr13	4001	----	----	410	202	94	670÷885
	X5CrNi1810	4301	Z5CN18.09	304 C 12	304	202	94	590÷685
	X8CrNi1910	----	----	----	----	202	94	540÷685
	X8CrNiMo1713	4401	Z6CDN17.12	316 S 16	316	202	94	490÷685
Copper alloys Special brass Bronze	Aluminium copper alloy G-CuAl11Fe4Ni4 UNI 5275					220	98	620÷685
	Special manganese/silicon brass G-CuZn36Si1Pb1 UNI5038					140	77	375÷440
	Manganese bronze SAE43 - SAE430					120	69	320÷410
	Phosphor bronze G-CuSn12 UNI 7013/2a					100	56,5	265÷314
Cast iron	Gray pig iron		G25		----	212	96	245
	Spheroidal graphite cast iron		GS600		----	232	100	600
	Malleable cast iron		W40-05		----	222	98	420

## 9.3 - Teeth pitch

As already stated, this depends on the following factors:

- hardness of the material
- dimensions of the section
- thickness of the wall.

	S (MM)	PICTH	SHAPE	SPEED
	up to 2	4 - 6	B shaped	2
	2 ÷ 5	8	C solid	2
	5 ÷ 10	8	C solid	1
	over 10	8	C solid	1
	up to 20	8	C solid	1
	20 ÷ 50	10	C solid	1

## 9.4 - Cutting and advance speed

The cutting speed (m/min) and the advance speed (cm<sup>2</sup>/min = area travelled by the disk teeth when removing shavings) are limited by the development of heat close to the tips of the teeth.

- The cutting speed is subordinate to the resistance of the material ( $R = N/mm^2$ ), to its hardness (HRC) and to the dimensions of the widest section.
- Too high an advance speed (= disk descent) tends to cause the disk to deviate from the ideal cutting path, producing non rectilinear cuts on both the vertical and the horizontal plane.

## 9.5 - Running in the disk

When cutting for the first time, it is good practice to run in the tool making a series of cuts at a low advance speed (= 30-35 cm<sup>2</sup>/min on material of average dimensions with respect to the cutting capacity and solid section of normal steel with  $R = 410-510 N/mm^2$ ), **generously spraying the cutting area with lubricating coolant.**

## 9.6 - Disk structure

The most commonly used disks are made of extra high speed steel (HHS) of **normal quality** (HHS/DMo5) or **superior quality** (HHS/Mo5 + Co5) with a treated tooth, which differentiates them from the former on account of the high value of structural resistance, greater resistance to seizing, absence of stress in the mass and a better holding of lubricating coolant during work.

## 9.7 - Type of disks

The disks differ essentially in their constructive characteristics, such as:

- Tooth shape
- Tooth cutting angle

### Tooth shape

The profile of the tothing depends on the size, shape and thickness of the section to be cut, either straight or at an angle. It may also vary according to the pitch, but not so distinctly as to make this an element for classification.

- Fine tothing is to be chosen for cutting small sections with a profiled shape and tubular sections with thin walls (2-5 mm depending on the material).
- Large tothing is suitable for cutting medium and large solid sections or fairly thick profiled or tubular sections (over 5 mm).

"A" tothing:  
normal fine tothing



"AW" tothing:  
fine tothing with alternate side rake



"B" tothing:  
normal large tothing with or without shaving breaking incision



"BW" tothing:  
large tothing with alternate side rake



"C (HZ)" tothing:  
large tothing with roughing tooth with rake on both sides, alternating with a finishing tooth without rake. The roughing tooth is 0.15-0.30 mm higher



Added tothing:  
disks made in this way are used for cutting non-ferrous metals, such as light alloys, and plastics, and above all in wood-working. The teeth are hard metal (HM) plates brazed onto the body of the disk; there are various types and shapes and, considering the vastness of the field, the topic is not developed further here.

### Tooth cutting angle

Each tooth has two cutting angles:

- $\alpha$  : front rake angle
- $\gamma$  : rear rake angle

### SHARPENING CIRCULAR SAWS

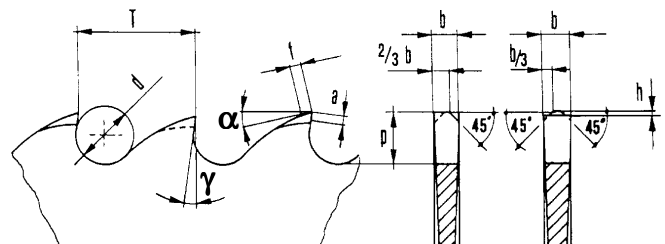

T	3	4	5	6	7	8	9	10	12	14	16
p	1,3	1,6	2,1	2,5	2,9	3,4	3,8	4,2	5,1	5,9	7,2
d	1,5	2	2,5	3	3,5	4	4,5	5	6	7	8
h = 0,2 mm						h = 0,3 mm					

The rake varies especially according to the type of material to be cut.



## 9.7.1 - RECOMMENDED CUTTING PARAMETERS

CUTTING ANGLES			γ	20°	18°	15°	12°	10°	12°	15°	12°	22°	20°	20°	15°	12°	16°	12°	18°	18°	15°
			α	8°	8°	8°	6°	6°	8°	6°	8°	8°	10°	8°	10°	8°	8°	16°	16°	8°	8°
SECTION TO BE CUT (IN MM)	10 - 20	*T mm	5	4	4	3	2	4	4	4	4	6	5	6	5	4	5	5	4	3	2
		Vt m/1'	50	30	20	15	9	20	20	25	1100	200	400	400	120	600	500	50	19	35	
		Av mm/1'	160	130	110	60	35	50	50	100	1800	400	600	800	160	1100	700	160	130	130	
	20 - 40	*T mm	7	6	6	4	3	6	6	6	6	8	7	8	7	8	6	7	4	4	3
		Vt m/1'	45	30	20	15	9	19	19	23	1000	180	350	400	110	600	400	45	18	33	
		Av mm/1'	150	120	110	60	33	45	45	100	1700	400	600	700	150	1100	600	150	120	120	
	40 - 60	*T mm	10	9	8	6	4	8	8	8	8	12	10	11	10	8	10	10	6	5	4
		Vt m/1'	45	25	18	14	9	18	18	22	900	160	300	350	100	550	350	45	18	30	
		Av mm/1'	140	110	100	50	30	45	45	90	1600	350	550	700	140	1000	600	140	110	110	
	60 - 90	*T mm	12	12	11	9	6	11	11	11	16	12	14	12	10	12	12	10	6	5	
		Vt m/1'	40	25	17	14	8	17	17	20	800	160	250	300	90	550	350	45	17	30	
		Av mm/1'	130	110	50	50	28	40	40	80	1400	300	550	600	130	900	500	130	110	110	
	90 - 110	*T mm	14	14	14	12	8	14	14	14	18	14	17	14	12	16	16	12	6	5	
		Vt m/1'	40	20	15	13	8	15	15	19	700	140	200	250	70	500	300	40	16	28	
		Av mm/1'	110	100	80	45	25	40	40	880	1300	300	500	600	110	900	500	110	100	100	
	110 - 130	*T mm	16	16	16	14	10	16	16	16	20	16	18	16	14	18	18	14	8	6	
		Vt m/1'	35	20	14	13	7	14	14	17	600	130	150	200	60	500	300	35	16	26	
		Av mm/1'	100	90	70	45	25	35	35	70	1100	250	500	500	100	800	400	100	90	90	
	130 - 150	*T mm	18	16	16	14	12	16	16	16	20	16	20	18	16	18	18	16	10	6	
		Vt m/1'	30	15	12	12	7	12	12	16	500	130	120	150	50	450	200	30	15	24	
		Av mm/1'	90	80	60	40	22	35	35	60	900	250	400	400	90	800	400	90	80	80	
	RECOMMENDED LUBRICANTS			Emulsion - Cutting oil								Dry	Kerosene Dry		Emulsion			Cutting oil		Emulsion	

## 9.7.2 - DIAGRAM OF CUTTING SPEEDS ACCORDING TO DISK DIAMETER

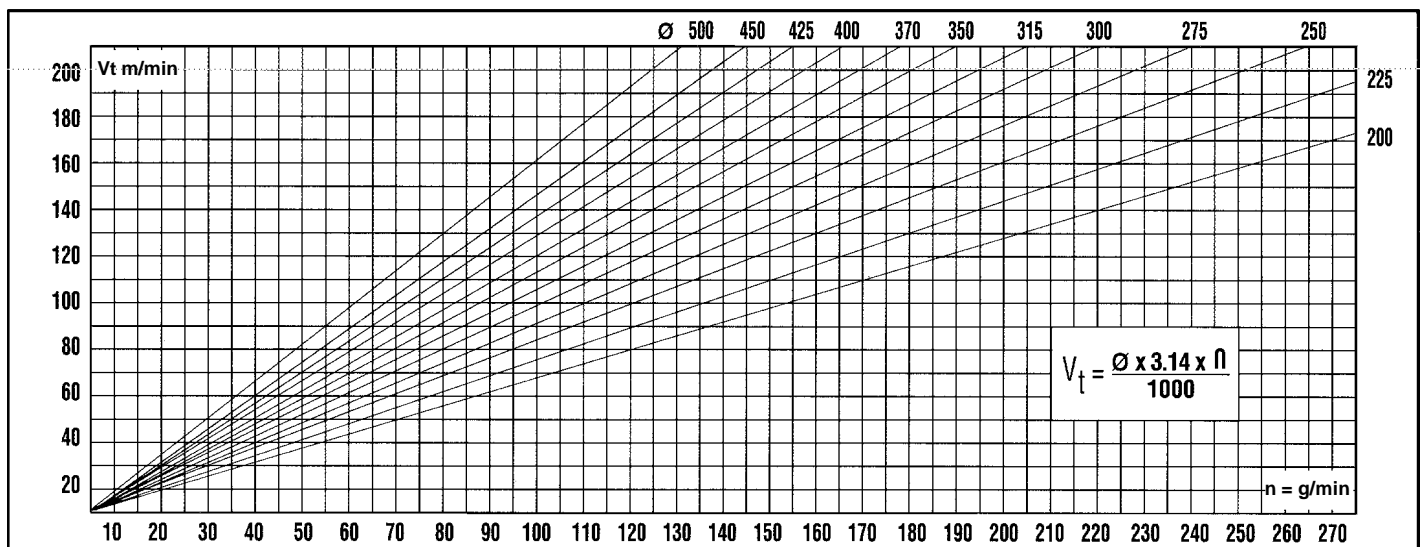

### KEY

T	Tooth pitch in millimetres	d	Diameter of the tooth fillet cone distance
Av mm/min	Advance in millimetres per minute	h	Tooth protrusion
Vt m/min	Cutting speed in metres per minute	γ	Front rake
Az	Tooth advance	α	Rear rake
Ng/min	Number of revs per minute	N/mm	Ultimate tensile stress
Z	Number of teeth on the disk	a-f	Flat parts of the cutting edge
p	Tooth depth	Ø	Tube diameter or profile width



## 10 MACHINE COMPONENTS

### 10.1 - List of spare parts

REFERENCE N°	DESCRIPTION	REFERENCE N°	DESCRIPTION
1	Machine bed	38	Burr-free plate
2	Revolving arm	39	Grain M8
3	Revolving arm locking pin	40	Screw M8
4	Revolving arm locking bush	41	Tank filter
5	Revolving arm locking lever	42	Screw M6
6	Screw M8	43	Bar stop rod
7	Countervice	44	
8	Pin	45	
9	Countervice jaws	46	Bar stop
10	Burr-free jaws	48	Screw M8
11	Countervice fixing pin	49	Support tank cover
12	Roller arm	50	Ring seeger Ø 42 I
13	Roller	51	Tank cover filter
14	Washer M10	52	Tank cover filter
15	Vite M10	53	Tank cover
16		54	Washer
17	Vice	55	1/4" gas tap
18	Vice jaws	56	Coolant tube
19	Vice jaws washer	57	Oiler Ø 8
20	Screw M12	58	Return spring connection
21	Vice jaws washer	59	Head return spring
22	Screw M12	60	Nut M12
23	Grain M8	61	Screw M12
24	Lever bush	62	Head
25	Quick lock vice lever	63	plug
26	Thrust bearing AX 3047 + CP 3047	64	Oil level plug
27	Quick lock vice lever washer	65	Oil drain plug
28	Vice closing handwheel Ø 18	66	Screw M10
29	Elastic pin Ø 5	67	Hinge pin
30	Washer	68	Hinge pin washer
31	Screw M8	69	Hinge pin bush
32		70	Grain M8
33		71	Nut M8
34		72	Nut M16
35	Vice thread	73	Head lever
36	Lock vice spring	74	Head lever handgrip
37	Burr-free transverse plate	75	GUK ring nut M25x1,5
		76	Worm wheel



REFERENCE N°	DESCRIPTION
77	Ring SM 35-47-7
78	Blade shaft
79	Pin
80	Blade
81	Shaft flange stakes
82	Screw M12
83	Fixed blade guard
84	
85	
86	Coolant distributor
87	Coolant tube
88	Grain M6
89	Mobile blade guard
90	Ring seeger Ø 60E
91	
92	
93	Tir rod support
94	Washer
95	Screw M8
96	Mobile guard rod
97	Screw M8
98	Washer
99	Bearing 6301
100	GUK ring nut M17x1
101	Worm screw
102	Spacer
103	Spacer Ø 47
104	Bearing 3204
105	Ring DPSM 25-40-7
106	Head gasket
107	Front motor flange
108	Motor shaft (rotor)
109	Key
110	Washer
111	Stud bolt
112	Nut
113	Motor and stator casing
114	
115	
116	Rear motor flange
117	

REFERENCE N°	DESCRIPTION
118	
119	Bearing 6205 2Z
120	Ring seeger Ø 25E
121	Fan
122	Screw M4
123	Fan cover
124	Bearing 609
125	Pump connection box
126	
127	Screw M5
128	Coolant pump
129	Washer
130	Screw M6

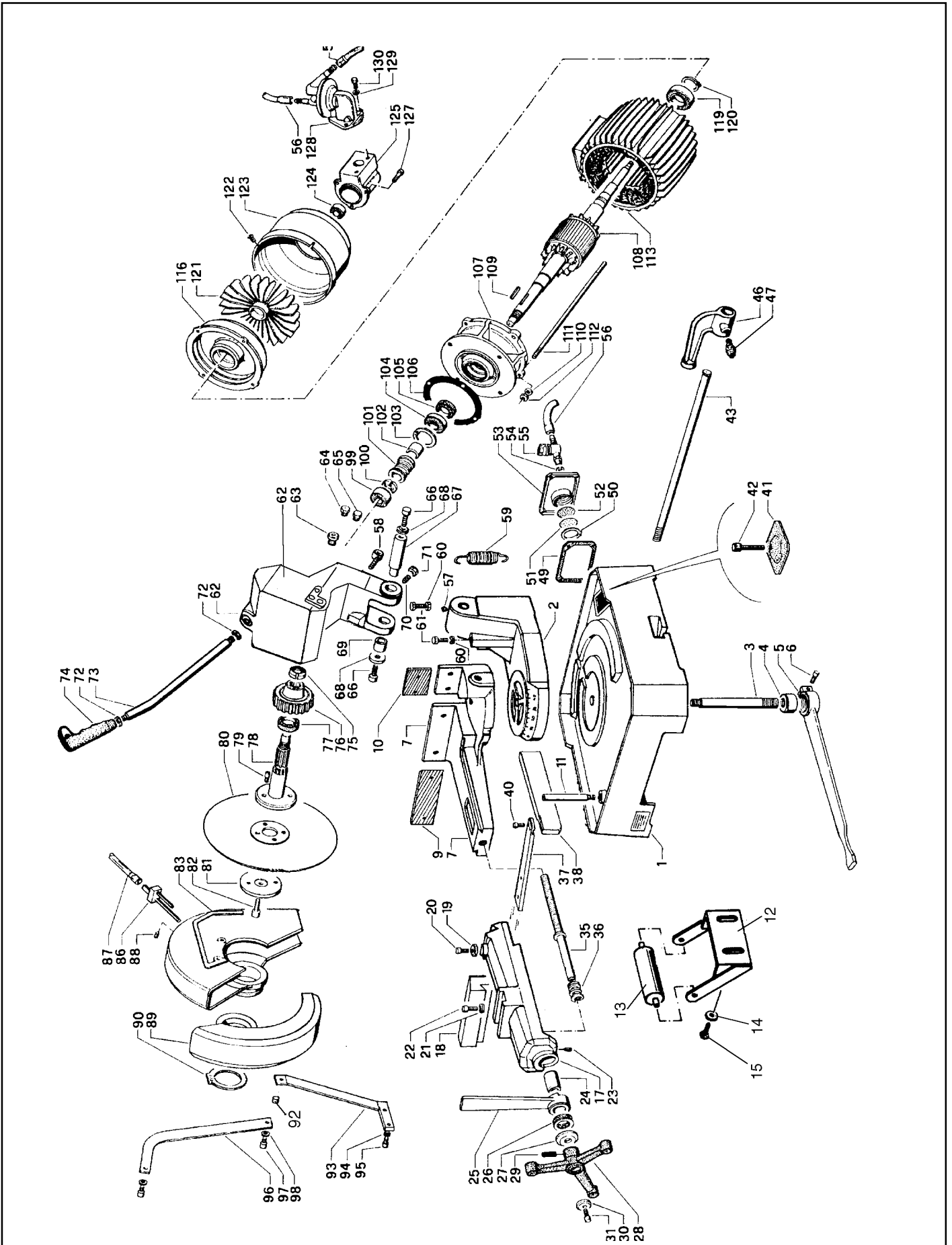

**LEGENDA**

- 140 Auxiliary relay
- 141 Remote control switch
- 142 Fuse carrier
- 143 Transformer
- 144 Socket connector
- 145 Plug connector

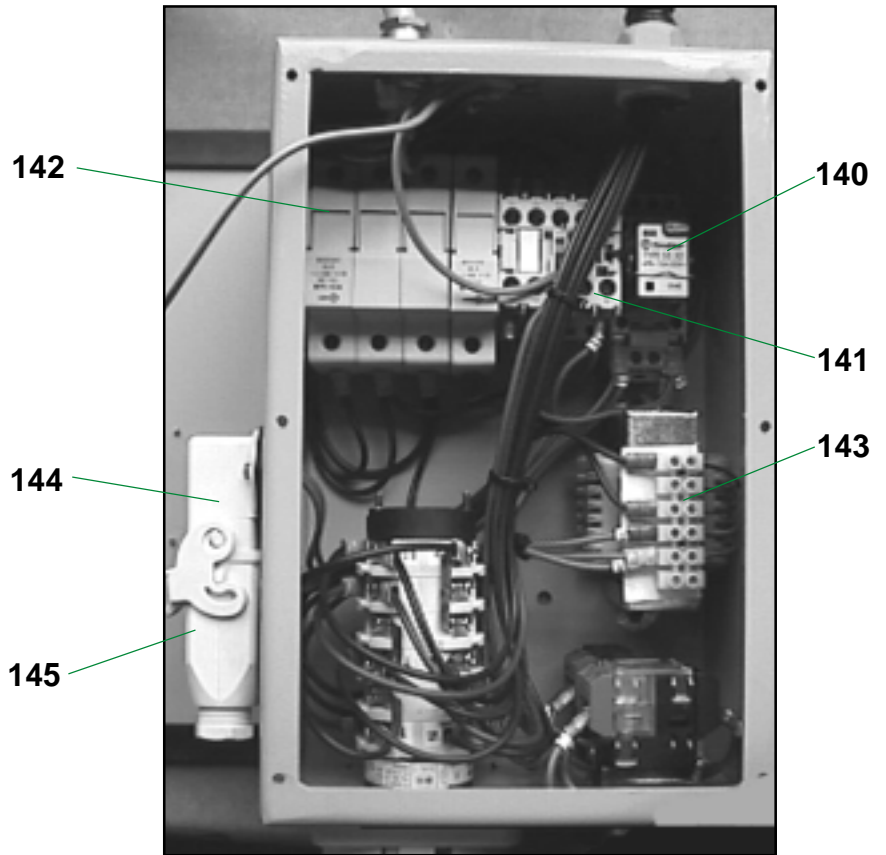

**LEGENDA**

- 146 Speed switch
- 147 Reset button
- 148 Emergency push button
- 149 Electric components box







## 12 TROUBLESHOOTING

This chapter lists the probable faults and malfunctions that could occur while the machine is being used and suggests possible remedies for solving them.

The first paragraph provides diagnosis for TOOLS and CUTS, the second for ELECTRICAL COMPONENTS.

### 12.1 - Blade and cut diagnosis

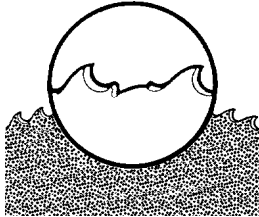
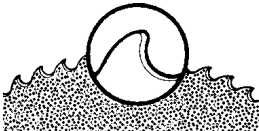
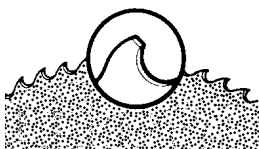
FAULT	PROBABLE CAUSE	REMEDY
<p><b>TOOTH BREAKAGE</b></p> 	<p>Too fast advance</p> <p>Wrong cutting speed</p> <p>Wrong tooth pitch</p> <p>Low quality disk Ineffective gripping of the part in the vice.</p> <p>Previously broken tooth left in the cut Cutting resumed on a groove made previously.</p> <p>Insufficient lubricating refrigerant or wrong emulsion</p> <p>Sticky accumulation of material on the disk.</p>	<p>Decrease advance, exerting less cutting pressure</p> <p>Change disk speed and/or diameter. See Chapter "<b>Material classification and choice of disks</b>" and the <i>Table of cutting speeds according to disk diameter</i>. Choose a suitable disk. See Chapter "<b>Material classification and choice of disks</b>".</p> <p>Use a better quality disk. Check the gripping of the part.</p> <p>Accurately remove all the parts left in. Make the cut elsewhere, turning the part.</p> <p>Check the level of the liquid in the tank. Increase the flow of lubricating refrigerant, checking that the hole and the liquid outlet pipe are not blocked. Check the blend of lubricating coolant and choose a better quality disk.</p>
<p><b>PREMATURE DISK WEAR</b></p> 	<p>Wrong running in of the disk</p> <p>Wrong cutting speed</p> <p>Unsuitable tooth profile</p> <p>Wrong tooth pitch</p> <p>Low quality disk Insufficient lubricating refrigerant</p>	<p>See Chapter "<b>Material classification and choice of disks</b>" in the paragraph on <i>Running in the disk</i>. Change disk speed and/or diameter. See Chapter "<b>Material classification and choice of disks</b>" and the <i>Table of cutting speeds according to disk diameter</i>. Choose a suitable disk. See Chapter "<b>Material classification and choice of disks</b>" in the paragraph on <i>Type of disks</i>. Choose a suitable disk. See Chapter "<b>Material classification and choice of disks</b>".</p> <p>Use a better quality disk. Check the level of the liquid in the tank. Increase the flow of lubricating refrigerant, checking that the hole and the liquid outlet pipe are not blocked.</p>
<p><b>CHIPPED DISK</b></p> 	<p>Hardness, shape or flaws in the material (oxides, inclusions, lack of homogeneity, etc.)</p> <p>Wrong cutting speed</p> <p>Wrong tooth pitch</p> <p>Vibrations Disk incorrectly sharpened</p> <p>Low quality disk</p>	<p>Reduce the cutting pressure and/or the advance.</p> <p>Change disk speed and/or diameter. See Chapter "<b>Material classification and choice of disks</b>" and the <i>Table of cutting speeds according to disk diameter</i>. Choose a suitable disk. See Chapter "<b>Material classification and choice of disks</b>".</p> <p>Check gripping of the part. Replace the disk with one that is more suitable and correctly sharpened. Use a better quality disk.</p>

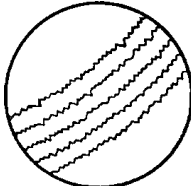
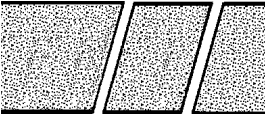

FAULT	PROBABLE CAUSE	REMEDY
	Incorrect emulsion of the lubricating refrigerant	Check the percentage of water and oil in the emulsion.
<b>DISK VIBRATION</b>	Wrong tooth pitch	Choose a suitable disk. See Chapter <b>“Material classification and choice of disks”</b> .
	Unsuitable tooth profile	Choose a suitable disk. See Chapter <b>“Material classification and choice of disks”</b> in the paragraph on <i>Type of disks</i> .
	Ineffective gripping of the part in the vice.	Check the gripping of the part.
	Dimensions of the solid section too large with respect to the maximum admissible cutting dimensions	Abide by the instructions.
	Disk diameter incorrect and/or too large	Decrease the disk diameter, adapting it to the dimensions of the part to be cut; the cutting part of the disk must not be too large for the shape of the part to be cut.
<b>RIDGES ON THE CUTTING SURFACE</b>	Disk diameter incorrect and/or too large	Decrease the disk diameter, adapting it to the dimensions of the part to be cut; the cutting part of the disk must not be too large for the shape of the part to be cut.
	Ineffective gripping of the part in the vice.	Check the gripping of the part.
	Too fast advance	Decrease advance, exerting less cutting pressure.
	Disk teeth are worn	Sharpen the tool.
	Insufficient lubricating refrigerant	Check the level of the liquid in the tank. Increase the flow of lubricating refrigerant, checking that the hole and the liquid outlet pipe are not blocked.
	Toothing does not unload shavings well	Choose a blade with a larger tooth pitch that allows better unloading of shavings and that holds more lubricating refrigerant.
<b>CUTS OFF THE STRAIGHT</b>	Too fast advance	Decrease advance, exerting less cutting pressure.
	Ineffective gripping of the part in the vice	Check the gripping of the part which may be moving sideways.
	Disk head off the straight	Adjust the head.
	Disk sides differently sharpened.	Choose tool quality carefully in every detail as regards type and construction characteristics.
	Disk thinner than the commercial standard.	Carefully clean the laying and contact surfaces.
	Dirt on the gripping device	
<b>BLADE STICKS IN THE CUT</b>	Too fast advance	Decrease advance, exerting less cutting pressure.
	Low cutting speed	Increase speed.
	Wrong tooth pitch	Choose a suitable disk. See Chapter <b>“Material classification and choice of disks”</b> .
	Sticky accumulation of material on the disk.	Check the blend of lubricating coolant and choose a better quality disk.
	Insufficient lubricating refrigerant	Check the level of the liquid in the tank. Increase the flow of lubricating refrigerant, checking that the hole and the liquid outlet pipe are not blocked.



## 12.2 - Electrical components diagnosis

FAULT	PROBABLE CAUSE	REMEDY
<b>THE GREEN PILOT LIGHT "HL" DOES NOT LIGHT UP</b>	<p>Fused lamp Power supply</p> <p>Fuses "FU 1" Short circuits Speed switch "SA" in position "0" Emergency button "SB 1" on</p> <p>Cycle reset or line button "SB 2" Thermal probe built into the stator winding has tripped due to motor overheating</p> <p>Transformer "TC 1"</p> <p>Fuse "FU 2"</p> <p>Auxiliary relay "KA"</p>	<p>Change it. Check: - phases - cables - socket - plug</p> <p>Voltage must arrive upstream from the fuses. Check for efficiency. Identify and eliminate. It must be turned to position 1 or 2. Ensure that it is off and that its contacts are unbroken. Check mechanical efficiency. Check current continuity on the two wires in the prone after letting the motor cool for about 10-15 minutes. If after this time there is no current continuity in the two wires, the motor must be changed or rewound. Check that the supply voltage is the same as the line voltage and that it gives a value of 24 V at output. Check fuse efficiency and ensure there are no short circuits causing the protection to trip. Check that 24 V reach the coil terminals when the button "SB 2" is pressed; if this happens and the relay is not self-fed, it must be changed.</p>
<b>MOTOR STOPPED WITH PILOT LIGHT "HL" LIT</b>	<p>Socket and plug connecting the electric box/ microswitch in the handle</p> <p>Microswitch "SQ 1" in the handle</p> <p>Remote-control switch "KM"</p> <p>Motor "M 1"</p>	<p>Check that the plug is correctly inserted and look for any bad connections inside the box. Check operation and/or efficiency; replace if broken. Check that phases are present at both input and output; ensure that it is not blocked, that it closes when fed, that it does not cause short circuits; otherwise change it. Check that it is not burnt and that it turns freely. It may be rewound or changed.</p>

# 13 NOISE TESTS

In accordance with point 1.7.4.f of the Machines Directive EEC 89/392

SOUND LEVEL CALIBRATOR MOD. BRUEL & KIAER 2260

2 measurements with the machine.

- The microphone was been located close to the operator's head, at medium height.

- The weighted equivalent continuous acoustic pressure level was 71,6 dB (A).

- The maximum level of the WEIGHTED instantaneous acoustic pressure C was always less than 130 dB.

NOTE: with the machine operating, the noise level will vary according to the different materials being processed. The user must there-fore assess the intensity and if necessary provide the operators with the necessary personal protection, as required by Law 277/1991.



## 14 OPTIONAL

### 14.1 - Pneumatic vice

- System for clamping material during the cutting operations, with an automated pneumatic device. It is provided with an anti-burr device for blocking the part of the piece that has been cut off.

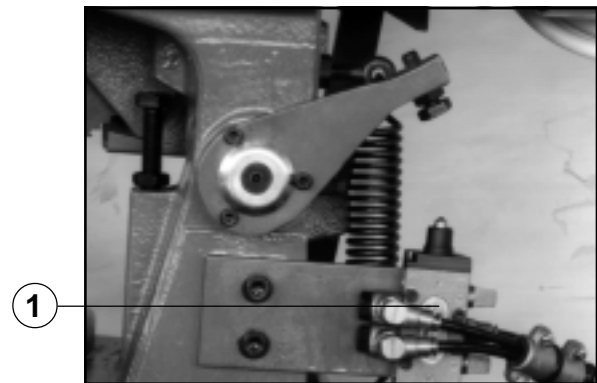
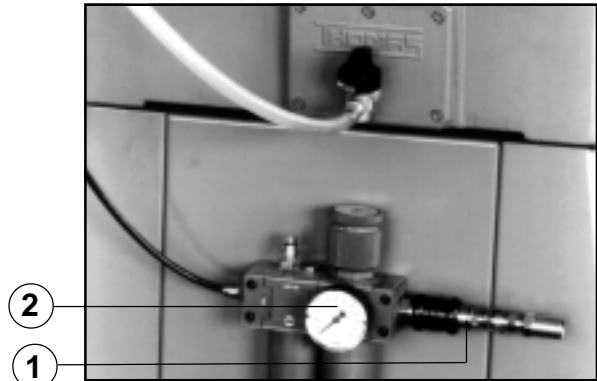
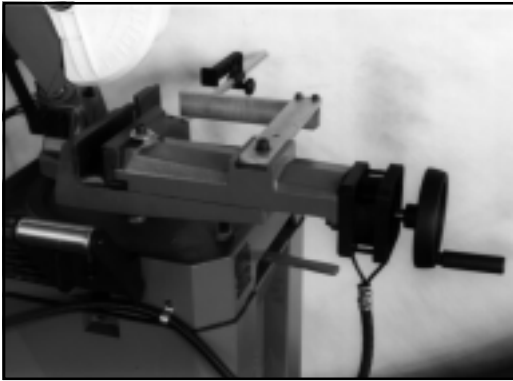

### 14.2 - Connection to the pneumatic system

- Connect the tube of the pneumatic system to the filter unit part ( 1 ) and check that the pressure gauge part ( 2 ) shows a pressure of 6 - 7 BAR, sufficient to ensure optimum functioning of the device.

- The vice opening mechanism is controlled by the valve part ( 1 ) operated only if the head is completely lifted.
- Leave a play of 3 - 4 mm between the jaws and the piece to be clamped, then lower the head to block the piece.

## PLATES AND LABELS

